

FENDT



FENDT® 300 VARIO SERIES | 100 to 132 Rated HP

Adaptability. Capability. Profitability.



Quick specs and features.

Specs

Base Weight lbs./kg	10,600/4,808
Rated Engine HP/kW	100/74–132/97
Engine	AGCO Power™ 4.4L, 4 cylinder, Tier 4F
Max Ballast lbs./kg	18,700/8,482
Loader Payload lbs./kg	4,960/2,250
Max Speed MPH/KPH	25/40

- Vario® CVT Transmission
- FendtONE™ Operator's Station
- Cargo Profi Loader
- Optional front 3-point and Hydraulics
- Front Axle Suspension

All the Fendt® capability packed into a very capable size.

The Fendt 300 has a long history of serving customers globally with all the key innovations that Fendt is known for, like our Vario CVT transmission, suspension systems, and unmatched fuel efficiency, but in a more compact design. The 300 features the all-new FendtONE driver's workstation, that delivers ultimate comfort, control, and convenience, thanks to a highly customized operating environment. This series is perfect for dairy farms, livestock operations, feedlots, as well as municipalities and specialty applications that demand unmatched performance, quality and adaptability,

What makes a Fendt a Fendt?

Quality is at the heart of everything we do.



All of our Fendt high horsepower tractors come out of our state-of-the-art manufacturing facility in Marktoberdorf, Germany.

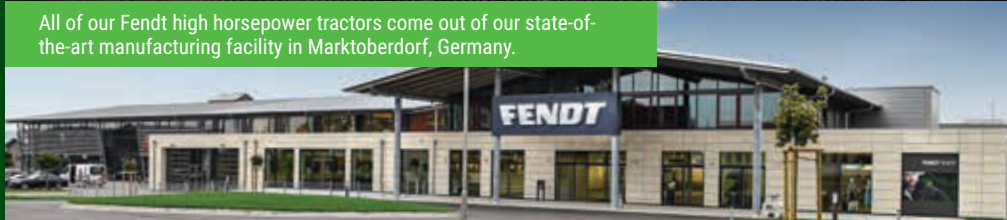

A long history of innovations that deliver superior performance and efficiency.



The powerful four-cylinder engine maximizes efficiency through its Tractor Management System (TMS); set the desired speed, activate the TMS and the system automatically adjusts for optimum performance.

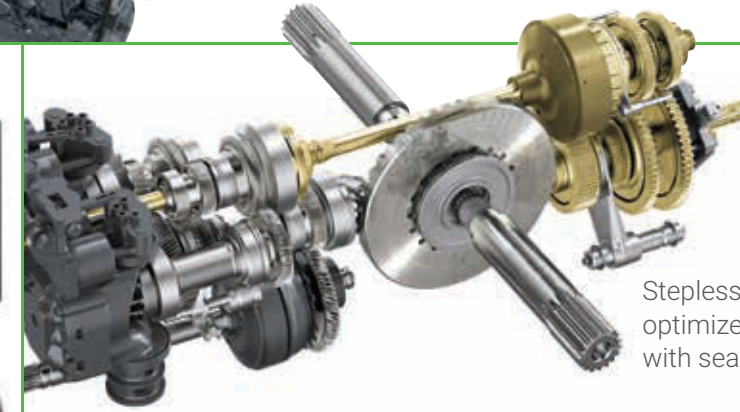

Stepless Vario® CVT, with no clutch packs, optimizes engine power and fuel economy, with seamless travel from 65 ft/h to 25 mph.

With a 10" digital dashboard standard and optional 12" armrest touchscreen terminal, paired with a customizable multi-function joystick, everything you need to operate the tractor is right at your fingertips.



Racecar-influenced, self-leveling front-axle suspension system, with more than 3.9-in. of travel, coupled with a second-to-none pneumatic cab suspension and air-ride seat provides the sophisticated comfort of a luxury pickup truck, even in the field.

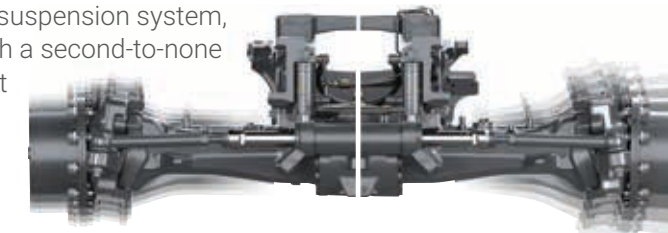

The best warranty in the business—three-year/3,000-hour full-machine warranty, PLUS all scheduled maintenance and a loaner guarantee.



A smart, factory-installed loader that actually improves precision and saves you money.

Fendt 300 Vario spotlights. Special. Better.

A Fendt 300 Vario is characterized by its thoughtful design, down to the last detail. This latest generation includes four models—in Max hp from 113 to 152 hp—in three configurations from a base level package, Power, to a fully loaded version with Profi+. This overview shows the special Fendt solutions—our Fendt Spotlights—that make the difference and simply make your work better every day.

1. VisioPlus™ cab: perfect all-round view

The panoramic front windshield provides an unmatched view that's great for any application, but especially when using a loader.

2. FendtONE™ driver's workstation—intuitive operation

All controls units are centralized on the dashboard and armrest with a multifunction joystick. Customize the entire workstation with freely assignable buttons. Option to upgrade to fully integrated 12" terminals on the armrest and in the roof liner.

3. Fendt DynamicPerformance: smart added power concept

For greater area coverage and higher productivity. Extra power boost of up to 10 HP on the 314 Vario at any speed.



4. Intelligence that Extends Beyond the Tractor

The optional CargoProfi loader takes loader operation and comfort to a whole new level with dampening suspension, memory settings, and an integrated scale feature.

5. Fendt Guide auto-steering for unrivaled productivity

With SectionControl, VariableRateControl, Contour Assistant and TaskDoc®. Access the same innovative solutions across all your Fendt tractors.

6. FendtONE™—seamlessly connecting machine and office

FendtONE—new driver's operator area combines machine operation, communication and documentation with the office in one unit. 4 modules: Guidance System, Agronomy, Telemetry, Machine Control.

7. Pull More, but Tread Lightly

Soil compaction reduces yield—a fact that applies both to arable farming and grassland. Extensive tire options and the low weight-power ratio of the Fendt 300 Vario results in greater adaptability but lower soil compaction. At just 11,045 lbs. or 73 lbs./hp, the Fendt 314 Vario makes a big impact without leaving one.

8. Superior Comfort and Control

Smart 4-in-1 system: self-leveling front axle suspension, optional mechanical or pneumatic suspension cab, active shock load stabilizing and Fendt Reaction steering.

9. Dedicated, Customized Hydraulic Power

Whether pulling a small planter or operating the loader, you have a 29 GPM dedicated pump to get the job done.

10. High ground clearance for crop protection

The Fendt 300 Vario offers a high ground clearance of up to 19.6 inches, making light work of special crop applications.



Fendt 314 Vario, 73 lbs./hp



One size doesn't need to fit all.

The Fendt 300 is the first series in North America to be offered in three different packages. This ensures that you can gain all the best performance and innovation from Fendt, tailored for your needs. The table to the right details the innovations included in each of the three packages offered today.



POWER



Power Version

- Crossgate lever
- No hydraulic fingertip controls

PROFI



Profi Version

- 3L joystick
- Hydraulic fingertip controls
- 12" terminal

PROFI+



Profi+ Version

- 3L joystick
- Hydraulic fingertip controls
- 12" terminal
- Fendt Guide

The images to the right represent the cab control configurations for the three different cab packages.

Cab & Technology Packages

Power—innovations	Profi—innovations	Profi+—innovations		
Top-end model 314 Vario with up to 152 hp engine output (ECE R120), 650 Nm; Fendt DynamicPerformance (DP)	Includes all of the Power innovations	Includes all of the Power and Profi innovations		
Efficient Tier 4 Final emissions technology with SCR, DOC, and a DPF without active regeneration				
Visctronic fan—up to 1.4% fuel savings compared to conventional fans				
Up to 25 mph at 1,550 RPM				
Adjustable multifunction armrest with controls on the driver's seat				
10" central digital dashboard; pushdial, 4 quick access keys				
2-way multifunction joystick with proportional hydraulic control, cruise control adjustment on pushdial				
Armrest keypad—keys assigned with flexible color coding; 5 freely assignable keys (IOM)				
Control panel for front + rear power lift with proportional control				
Up to four rear hydraulic remotes				
Self-leveling front axle suspension, lockable	+	+		
Up to 7% improved traction and increased area coverage				
4WD and automatic differential lock steering angle and speed-led				
FendtONE – Driver's workstation—Connect tractor controls with planning tasks from the office, all on the terminal				
			12" terminal on armrest, with touch and pushdial control	
			Second 12" terminal, optional in right side of roof liner, retracts half way	
			Infotainment, 4.1 sound system—AM/FM/DAB/Bluetooth®, USB, AUX—hands-free speaking system, superior audio quality	
			3L joystick	
				Fendt Guide tracking is the same from Fendt 300 Vario to 1000 Vario—end-to-end functionality
				Automated steering module—with tractor preparation and Fendt Guide for more productivity
		Contour Assistant with Single Track / Contour Segment control		
		Agronomy module: create and report jobs with TaskDoc Documentation and Task Manager control		
		Machine control module: simple control of ISOBUS attachments via ISO 11783 interface		
		Telemetry module: Fendt Connect: best analysis and fleet management		

Your favorite place with a wide view.



Panoramic front window with 77° vision for a full view upwards and over the wheel arches.



Optional right hand door opening.

VisioPlus™ cab: perfect all-round view

The Fendt VisioPlus cab is a true wonder of visibility and space, with a 77° panoramic view. The windshield arches into the roof without an obstructive cross bar, giving you a continuous view of the extended front loader.

Open or closed? Three cab configurations

You can have a door on the right-hand side too, for even more flexible entering and exiting. The advantages are that it's easier to clean the vehicle and quicker to hitch/unhitch the front loader. If you prefer a front window that opens, the Fendt 300 Vario offers one with a split window pane.

Optional cab suspension

A perfectly fine-tuned cab suspension is key to safe and easy driving and working. The optional mechanical cab suspension effectively minimizes vibrations and shocks. The optional pneumatic cab suspension included in the Profi and Profi+ packages features a self-leveling function at the rear for even suspension.

Unique Fendt crossover lighting for best illumination

The outside front work lights effectively prevent shadows. The secret lies in the unique Fendt crossover design of the front work lights. This successfully avoids glare from the hood and drop shadows, giving you a particularly broad field of light.

Pure ergonomics: multifunction joystick and crossgate lever

The new joystick has a total of 16 buttons as well as 2 proportional buttons. 13 of these can be freely assigned. This puts virtually all commonly used controls right at your fingertips.

Armrest control panel with color coded controls

Here you will find all functional groups in one place and functional groups assigned by color. There are also five freely assignable buttons so you can customize the controls.



Settings and overview in the dashboard

Shown here is the main digital dashboard where you can easily configure the main function groups. The newly designed digital dashboard includes all key machine information including road speed, engine speed, all fluid levels, and other operational elements.

Infotainment bundle with 4.1 sound system

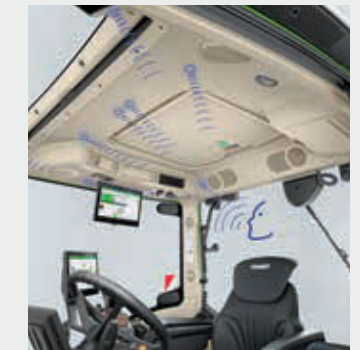

Four high-end speakers and a subwoofer deliver superior sound quality in the VisioPlus cab. Enjoy playback from your smartphone via USB, AUX-IN and Bluetooth. FM/AM/DAB+/HD and two antennas with permanent channel search also ensure uninterrupted radio reception. Make phone calls in your Fendt 300 Vario with a fantastic quality hands-free kit. Eight microphones installed in the roof liner mean your hands are free and the acoustics are perfect. Use the Varioterminal™ options and the side control dial.

More productive than a corner office.



Retractable roof terminal:

The optional 12" roof terminal on the right is linked to all the other terminals. You can shift the content so it works for you ergonomically. You can also partially push this terminal into the roof for a better overview on the road, so you can still use 50% of the display area for main views over three sections.



New 12" displays—more functions and display area

Depending on the equipment variant, the Fendt 300 Vario now features the 12" terminal, which includes all the guide-assist systems, such as Contour Assistant, SectionControl and VariableRateControl. The ever-increasing number of terminal applications means you need more display room in the tractor. Together with the new operating philosophy, the new Fendt 300 Vario features an optional second 12" terminal in the roof on the right-hand side. Up to 6 freely configurable screens are shown on the displays.



Crossgate lever and 3L joystick

There is a crossgate lever or 3L joystick to control the 3rd and 4th hydraulic control units as well as the front loader, depending on the configuration. The crossgate lever is only available with the Power version. With the 3L joystick, you can control the front loaders Fendt Cargo and Fendt CargoProfi, including their special functions.

As well as the familiar clover leaf operation, the new multifunction joystick includes two controls for proportional valve control as well as four freely assignable white keypads.

This is where you can easily manage the usual transmission and driving functions with pushbuttons: including two engine speed programs, two cruise control settings and a new dial-controlled active cruise control setting.

The 3L joystick offers sensitive control without you having to reach over two control valves. Complex implement functions can be controlled with the optional third and fourth hydraulic circuits. These are activated and controlled by pushbuttons on the joystick.

Five white buttons ready for you to assign: You have the option to freely assign functions to specific controls. Never before has the workplace seen this level of individualization for different operators.

You can easily manage the air conditioning and infotainment with three dedicated dials.



Use the central pushdial to decide what to display on the Fendt 300 Vario. This includes four quick access keys for Back, Launchpad, Overview, Individual Operation Manager (IOM) and switching between terminal and dashboard.

Here are the control buttons for the all-wheel drive, differential locks on the left, power-lift settings on the right and in the middle the five freely assignable white buttons.

In the middle operating level, from the left foot pedal max, we have the following: hand throttle, speed spread, adjustment SCVs 1 and 2 (freely assignable), PTO actuation as well as front power lifts and rear power lifts with depth adjustment.

PTO Operation

The lower control level includes the LED display for each setting. The driver immediately sees whether buttons have been re-allocated by the color concept. By default, these are the hydraulic valves.

Don't let its size fool you.

DynamicPerformance (DP), Fendt's added power concept for greater area coverage and higher productivity

The Fendt 314 Vario DP has a maximum engine power of 152 hp at an impressive torque of 479 ft./lbs. The innovative power-boost concept DP releases up to 10 hp more power when it's needed. It is not tied to driving speeds or special operational tasks, but works dynamically. Typically, the engine power of tractors is distributed across numerous power demands—such as the PTO, hydraulics, engine fans and air conditioning. The system detects when certain components need more power and then provides it through smart control. DP works at a standstill—such as with your feed mixer wagon—just as it does on the move. DP also kicks in for groundwork and for slow transport journeys according to the power required. The extra 10 hp is great for farms that want a compact, but powerful tractor with reserves.

Economical and low-maintenance

The fuel pre-filter with a thermostatic valve allows the tractor to start reliably, even at very low temperatures well below zero, since the pre-warmed fuel flows from the return into the prefilter. The radiator and filter are arranged for ease of maintenance.

Emission control with passive DPF, DOC and SCR

The SCR exhaust technology together with the passive diesel particulate filter (DPF) proves to be particularly fuel-saving because the DPF does not require additional diesel injection during regeneration. The additional injection of DEF reduces nitrogen oxides to a minimum. Combined with a diesel oxidation catalyst (DOC), emissions are reduced effectively and the tractor complies with the latest Tier 4 Final emissions standards.

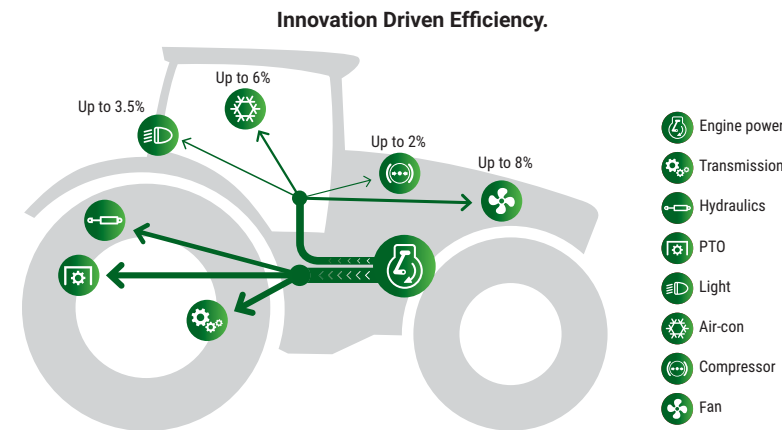

The smart power-boost concept Fendt DynamicPerformance (DP) on the Fendt 314 Vario releases up to 10 hp more power on demand. This is regulated depending on the operating conditions at any speed. You can also benefit from PTO power either at a standstill, for soil cultivation or during transport. The benefit is a lightweight tractor with more power and less fuel consumption per acre.



The new digital-control Visctronic fan adapts to changing conditions. This saves up to 1.4% in fuel and runs more quietly than a conventionally controlled fan. It also reduces repairs and increases service intervals even in dusty conditions.



Excellent accessibility for maintenance: Both the direct air supply and easy access to the foldable climate capacitor and coolers make it all extremely maintenance-friendly. The flat radiator floor ensures low sensitivity to dirt.



The large tank holds 55 gallons of diesel and 6 gallons of DEF for long-range results. Work longer without refuelling. Practical: The Diesel and DEF filler necks are located on the same side of the tractor.

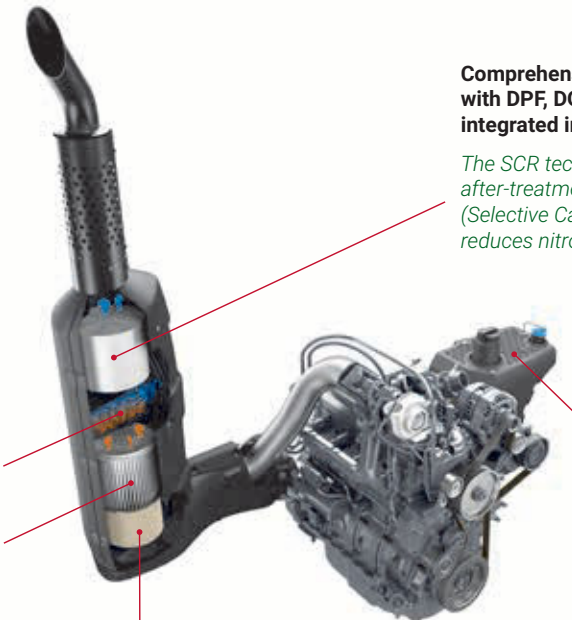

Comprehensive exhaust treatment with DPF, DOC and SCR fully integrated in the muffler:

The SCR technology for exhaust after-treatment with AdBlue injection (Selective Catalytic Reduction) reduces nitrogen oxide (NOx)

SCR injection
Passive diesel particulate filter with heat mode

Diesel oxidation catalyst (DOC)

6 gallon DEF tank

The heart and soul of every Fendt: Vario CVT transmission

Enjoy Vario added power—save up to 7% on time and 9% on diesel

The extra power of the Fendt Vario comes from always working at the perfect speed and optimum efficiency to achieve maximum area coverage. Independent publications show that this saves you up to 7% in working hours* and up to 9% diesel* compared to a powershift, depending on the type of farm. On a 250 acre forage operation, that's up to 46 working hours over six working days and 3,064 gallons of diesel** per year saved!†

Consistent, smooth ground speed control

From 65 ft./h to 25 mph the efficiency, control, and comfort of the Vario CVT is unmatched. Even on slopes, you can come to a smooth standstill thanks to the active stop control—gently and without any jolting. This works great in applications such as round baling, eliminating the need to use the clutch pedal and brake. Shuttling can be conducted from either the multifunction joystick or via the left shuttle lever.

Operate in joystick or pedal modes

Run the transmission the way you want. Joystick mode allows you to independently control ground speeds and engine speeds via the multifunction joystick—great for applications such as planting or tillage work. In pedal mode, the ground speed and engine speeds are independently controlled, but operated through the foot pedal, allowing it to function more like an automatic transmission in a car. This is ideal for loader work or grain cart work—quick starts and stops and frees up a hand for joystick operation.

The perfect duo: Tractor Management System (TMS) and automatic limit load 2.0

TMS controls the engine and transmission so that they are always effortlessly working at their best.

Rear: PTO with start-up control and lift height-dependent PTO automatic mode

For an implement-friendly take off, just preset the start-up control electro-hydraulically at the push of a button. Another benefit is the PTO automatic mode, which switches on and off depending on the lift height.

Exclusive Fendt benefit: Rear PTO with external actuation and engine speed increase

Practical example of filling the manure tanker: Activate the PTO externally then increase the engine speed in the cab: now a thing of the past because the engine speed increases when you activate the PTO externally. The good news for you is you no longer have to keep getting in and out the cab.



Driving pedal or joystick control: The driving mode can be selected individually. The speed can be controlled with either the pedal or the joystick. Change drive direction either with the joystick or the reverse lever with built-in stop and go function.

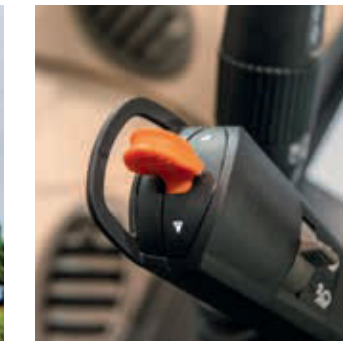

Left hand shuttle for easy and smooth direction change.



The Fendt Vario CVT provides a simple, proven design that eliminates wear components such as clutch packs. The PTO rotates independently of the transmission.



Superior productivity with Vario added power.

- Achieve the perfect working speed every time, even in changing conditions
- TMS—perfect engine/transmission management with automatic limit load 2.0
- Smooth reversing and speed matching
- 25 mph/40 kph at a quiet, fuel-saving 1,550 rpm
- Time savings of up to 7% and up to 9% less fuel compared to shift-gear designs

Because details make all the difference.

Superior driving and working comfort in a more compact design

The smart 3-in-1 system guarantees maximum ride comfort and ease-of-use: self-leveling front axle suspension, optional cab suspension and active shock load stabilizing. This is combined with the exclusive Fendt Reaction steering, which enables particularly sensitive and safe control and has excellent responses for safe straight-ahead driving.

Front axle suspension—up to 7% more area coverage and superior comfort

The self-leveling front axle suspension with 3.14 inch suspension guarantees optimum traction and increases your area coverage by up to 7%. The ever powerful Vario drive also delivers excellent comfort and stability, even on hillsides.

Self-leveling front axle suspension with full control

The integral automatic self-leveling with position sensor guarantees constant suspension comfort independent of load. The suspension can be completely deactivated at the touch of a button for any tasks that require particular accuracy and precision, e.g. loading work.

Safe driving, even with high payloads

The Fendt 300 Vario is based on a robust cast half-frame, which is designed for a permissible overall weight of 18,740 lbs. and a high payload of 7,716 lbs. The space-saving half-frame design creates the space required for the suspension with longitudinal arm, which provides especially high ride comfort.

Smart 4WD and automatic differential lock

The automatic steering and speed-dependent system for 4WD and the rear multi-disk differential lock is a huge help on the headland. Depending on the requirements, both systems are switched on or off based on steering angle or speed. The result is ultimate tractive power with full maneuverability.



Incredibly Tight Turning

The innovative half-frame design creates more space for an increased turning radius.



Self-leveling front axle suspension for greater area coverage and traction

The self-leveling, lockable front axle suspension is built as a vertical swingarm with 3.14 inch suspension. This design combines smooth running with optimum traction. An integrated position sensor, together with the self-leveling, ensures permanent traction and consistent driving comfort.



Automatic steering axle lock: This assist system unlocks the trailer's self-steering axle at a predefined speed. On straight stretches, the locked self-steering axle ensures stable handling. Operators do not need to lock the self-steering axle manually outside of the preselected speed range or when reversing.



At the headland or during front loading work, you benefit from VarioActive steering*, allowing you to achieve maximum turning radius with only one turn of the steering wheel.

Perfect loading combination.



Loader work never looked so good

The front windshield on the cab curves up into the roof for an unobstructed view of the front loader. The integrated curvature means any material just slides off.

Three front loader versions—Compact to Profi

The Cargo front loader is available in three versions for the 300 Vario: Cargo 4X75, 4X75 compact and CargoProfi 4X75. On the Compact 4X75, the arm is attached 4 inches closer to the cab, to increase stability.

Integrated Cargo dampening system

Gas pressure reservoirs absorb vibrations and shock loads so they are not transmitted to the tractor. This saves wear and tear on the tractor and ensures a long service life. The integrated dampening system together with front axle and cab suspension ensures superior driving comfort and makes front-loader work a real pleasure.

Perfect ergonomics: turn and steer on the left, load on the right.

The front loader controls are perfectly integrated into the overall design of the right armrest. Your left hand selects the driving direction while your right hand operates the crossgate lever for the front loader. Depending on the configuration, you can choose between a crossgate lever or the 3L joystick as the controller for the front loader. You can control the speed with your foot. With the reverser, you can change driving direction quickly and easily, without wear.



Front loader with dampening system

CargoProfi: smart and accurate loading to target weight and working height

Thanks to the precise measuring and tilt sensor system on the CargoProfi 4X75, you know exactly how much you are loading. Weigh your load at the touch of a button and make full use of the full loading capacity. This also saves the trip to the weighing station. The CargoProfi offers top and bottom limits for lifting height and tipping angle. Your bucket is emptied completely thanks to the integrated shake function, which loosens any stubborn material. The Memo function saves positions and makes frequently repeating jobs easier.

Limiting the tilt angle for safety: on the Fendt CargoProfi, you can limit the tilt angle when loading very high trailers. The Memo function is especially practical for repeating sequences, for example, the horizontal lower position can be targeted automatically. The weighing function gives you more control over the load weight.



You can operate the Cargo loader and shuttle vehicle direction conveniently using the new 3L joystick.

Foot pedal mode allows you to control ground speed and frees up your right hand for constant loader control with the 3L joystick.



With the orange reverse lever, the driver can easily change directions with their left hand. Hold the lever down and the Vario stops. Release the lever and the tractor automatically drives in the preset direction.



Fendt Cargo front loader		4X/75 compact	4X/75 ¹
A	Digging depth (tire-dependent)	in. 8.6	5.9
B	Excavation height (tire-dependent)	in. 160.8	163.5
C	Laying width at height of 3.5 m (tire-dependent)	in. 62.4	66.3
C	Laying width (tire-dependent)	in. 41.1	45.1
D	Dumping angle	degrees 55	55
E	Rollback angle	degrees 48	48
	Continuous lifting capacity	daN 1940	1940
	Max. lift capacity	daN 2250	2250

¹ Same values apply to Fendt CargoProfi

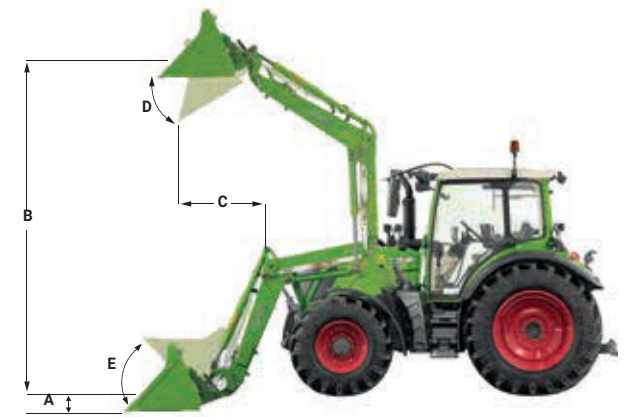

Fendt Guide auto steering and headland management.

For those who prefer precision.

You can configure your Fendt guidance system to suit your needs. Equip your system with either a NovAtel® or Trimble® satellite receiver. Depending on your work and individual requirements, you can choose from correction signals with different accuracy levels.

NovAtel receiver



NovAtel Standard
Correction signal: SBAS (EGNOS & WAAS)
± 6-11.8 inches track-to-track accuracy; ± 59 inches repeatable accuracy

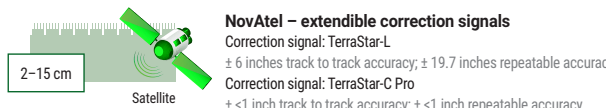

NovAtel – extendible correction signals
Correction signal: TerraStar-L
± 6 inches track to track accuracy; ± 19.7 inches repeatable accuracy
Correction signal: TerraStar-C Pro
± <1 inch track to track accuracy; ± <1 inch repeatable accuracy

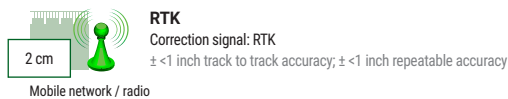

RTK
Correction signal: RTK
± <1 inch track to track accuracy; ± <1 inch repeatable accuracy
Mobile network / radio

Trimble receiver



Trimble Standard
Correction signal: SBAS (Egnos & Waas)
± 6-11.8 inches track-to-track accuracy; ± 59 inches repeatable accuracy

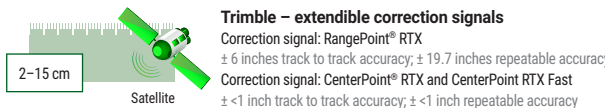

Trimble – extendible correction signals
Correction signal: RangePoint® RTX
± 6 inches track to track accuracy; ± 19.7 inches repeatable accuracy
Correction signal: CenterPoint® RTX and CenterPoint RTX Fast
± <1 inch track to track accuracy; ± <1 inch repeatable accuracy

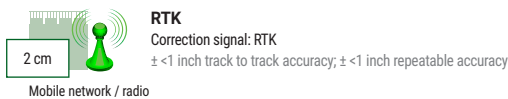

RTK
Correction signal: RTK
± <1 inch track to track accuracy; ± <1 inch repeatable accuracy
Mobile network / radio

Because the receivers are installed under the roof hatch, they are fully protected against theft, weather and damage.

Two main factors are decisive for farming:

- Track-to-track accuracy: Shows how precise the contacts are from one track to the next
- Repeatable accuracy: Specifies how accurately you can repeat an existing wayline or field boundary from the previous year.

Headland management made easy with Fendt TI and TI Auto

This smart assist is a real benefit for repeat processes, especially headlands. Our Fendt TI headland management system saves you up to 1,920 daily hand movements in 160 turns. Both manually at a standstill and while driving, you can record all the functions as a sequence and save them in the terminal. Later, all it takes is a touch of a button to activate the automated sequences when entering and coming out of the headland. Work without having to reposition. Five triggers (route, time, front power lift, rear power lift and manual) and 13 function groups help you control an impressive 74 functions. Shift smoothly between the individual sequence steps. Later, all it takes is a touch of a key to activate the automated sequences at the headland.

With Fendt TI in combination with Fendt Guide (Fendt TI Auto), position detection automatically initiates all recorded steps at the headland.

Work profiles for perfectly adjusted equipment, even with different operators working on the same machine

With the work profiles, you can save each implement with its own settings. This saves you from having to enter the settings each time. Even if you have different operators, they can then work efficiently and optimized without adjusting any settings. The numerous setting parameters include: power lift, PTO, hydraulics, maximum load control, cruise control, engine speed, 4WD and differential locks.

Agronomy.

Save time in the office.



Fendt TaskDoc: Get ahead of the paperwork

With the order-led documentation system Fendt TaskDoc®, your tractor collects all necessary data as you work. You can then transfer the data as a standardized file into a field map—either via a USB stick, Bluetooth or wirelessly over the mobile network.

Simple order management: Fendt Task Manager

With the basic agronomy package on your machine, you can create orders on the go or from the office in just a few clicks and send them wirelessly to the machine.

Machine control.

Perfect interaction of tractor and implement.



SectionControl (SC)

SectionControl ensures accurate seed or product placement based upon coverage maps.



Perfect interplay via ISOBUS:

SectionControl, VariableRateControl and the Fendt Guide Contour Assistant give you all the software you need for high-precision, quality work.

Fendt ISOBUS is a standardized plug & play interface between the tractor and the attachment: Simply connect the ISOBUS plug to the ISOBUS socket, and the control screen of the attachment appears in the terminal.

Pinpoint precision: Fendt SectionControl

SectionControl provides automated section control for ISOBUS implements. Fendt SectionControl supports up to 36 partial widths. The ISOBUS standard promises intuitive handling: The control screen automatically appears on the terminal when you connect the ISOBUS plug to the socket. All you need to do is activate a switch to start.

How you benefit from Fendt SectionControl

- Savings of up to 15% in resources by avoiding unwanted overlaps
- Reduces the threat of disease, pests and weeds by avoiding overly dense crops and missed sections
- Less effort for the driver, so they can fully concentrate on monitoring the implement
- Improves the quality of work with automatic and accurate swath control
- Headland mode: Option to work the inner field first, then the headland

Make full use of your tractor's potential: Fendt VariableRateControl (VRC)

VRC controls the output volume of resources (seeds, pesticides, fertilizers) for each subsection of field. To benefit from this smart solution, you need Fendt TaskDoc and an ISOBUS TC-GEO standard license.

The advantages of Fendt VariableRateControl

- Increase your efficiency: Maximize yield while saving resources
- Save time: Use the job report as a reporting basis to meet legal requirements (e.g. Fertilizer Regulations)
- Flexibility: Compatible with ISO XML and Shape files

No need for an external ISOBUS display

The additional 12" roof terminal offers you even more display space. You can show your ISOBUS attachment data on the roof display, for example, while the display on the armrest shows the lane guidance. External displays are no longer needed.



Fendt Guide Contour Assistant

The Fendt Guide Contour Assistant option adds Contour Segments and Single Track to the familiar wayline types.

Contour Segments wayline

Record each segment and track everything, or apply them directly from the existing field boundary.

- No need to record different waylines to edit different sections of the field
- No need to manually switch between waylines as you work the field
- Combine all relevant tracks in one
- Contour Assistant automatically detects the right track

Single Track wayline

Record an almost endless track with an open contour.

- Ideal for plant protection, as you can record a single track and apply it to the whole field

Telemetry.

Optimize your machine use.

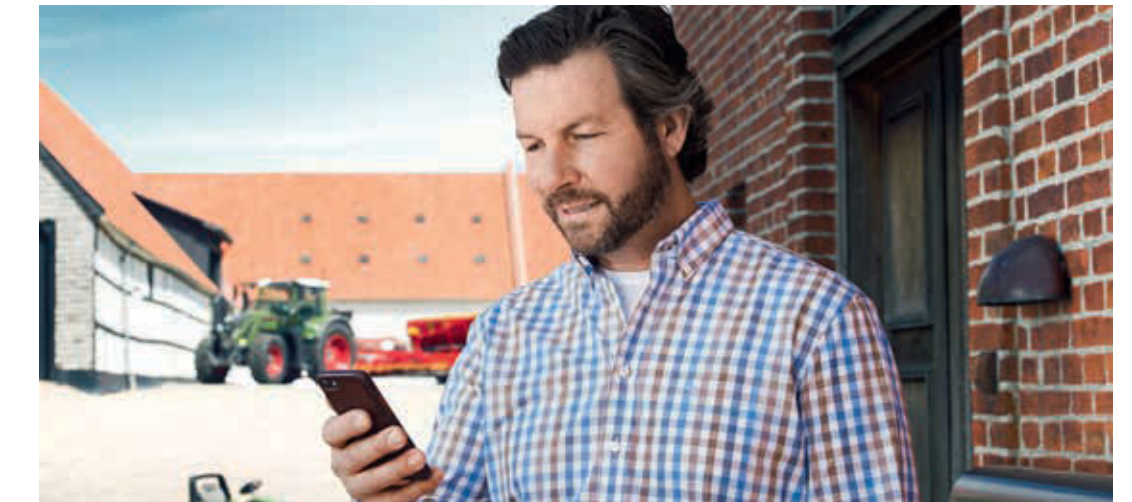

Call up machine data from any location: Fendt Connect

Fendt Connect is the central telemetry solution for Fendt machines. With Fendt Connect, machine data is collected and evaluated, so farmers and contractors can monitor, analyze and optimize the condition and use of their machines.

Fendt Connect tells you about:

- Machine position and route
- Fuel consumption and DEF level
- Speed and working time
- Machine capacity
- Error messages
- Upcoming service intervals

Fendt Connect

Mobile data transmission means you can check your realtime machine data anywhere—from a PC, tablet or smartphone.



Attachments at the front and rear.

Perfect tractor rear: 15 practical benefits that make all the difference

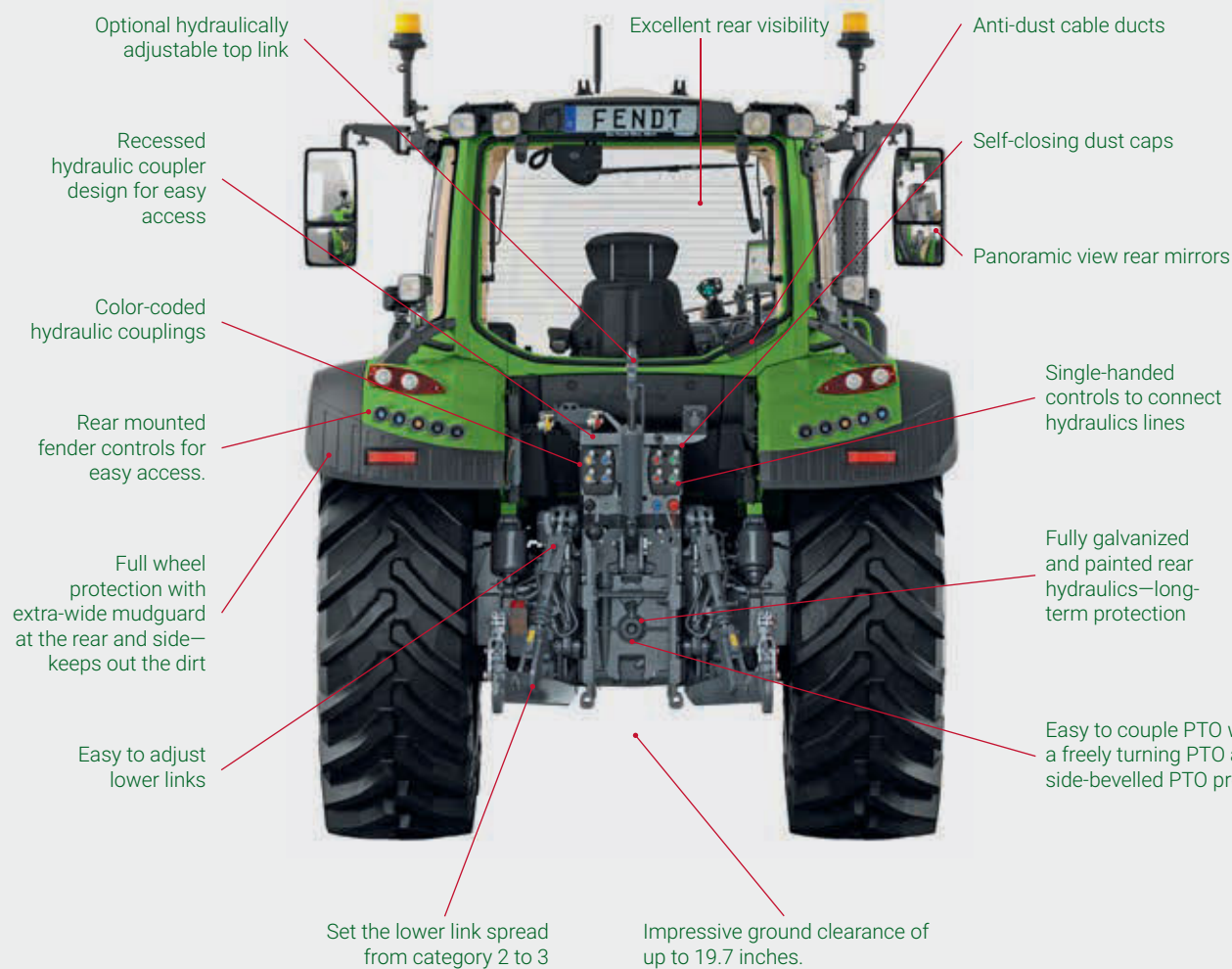

The rear power lift, PTO and one spool valve can be controlled from either rear fender.



Three high-quality integrated front power lifts:

- Standard, with position control and position and load-relief
- Sits particularly close to the vehicle, which means the entire hook-up is very maneuverable
- Max. lift capacity 3,130 daN
- Lower links with particularly good lower grip, fold in to park
- Lifting cylinder protected by bellows against stone impacts
- The vibration damping, fitted as standard, prevents bounce and guarantees driving comfort
- Top links with solid brackets and easy handling

Increased visibility and efficiency.

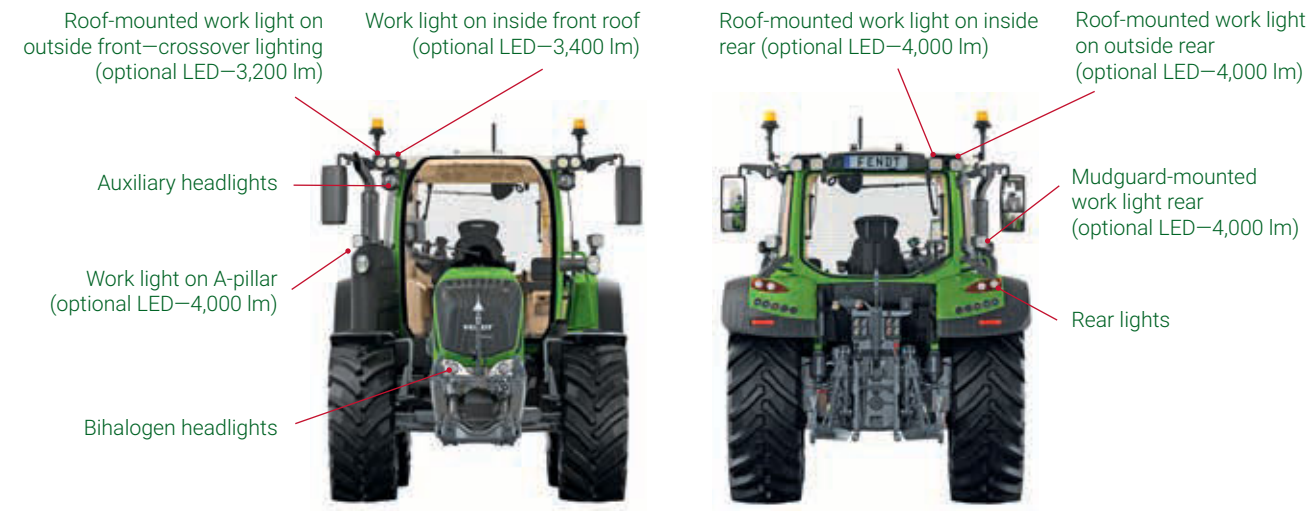

Extensive lighting system with Coming-Home function.

- Settings in Lighting menu on the dashboard
- Two programmable lighting modes
- Coming-Home function—adjustable timer

Up to six work lights at the rear. Optionally with high-quality LED work lights.

- Total lumens with the full LED equipment is 48,300 lumen of luminous flux
- All LED headlights are shock-proof, jetwash-resistant,
- EMC-tested (lane guidance, radio) and salt-spray tested

Cargo details at a glance:

Cargo-Lock with semi-automatic latch allows quick, bolt-free coupling and uncoupling with 1 or 2 hand movements

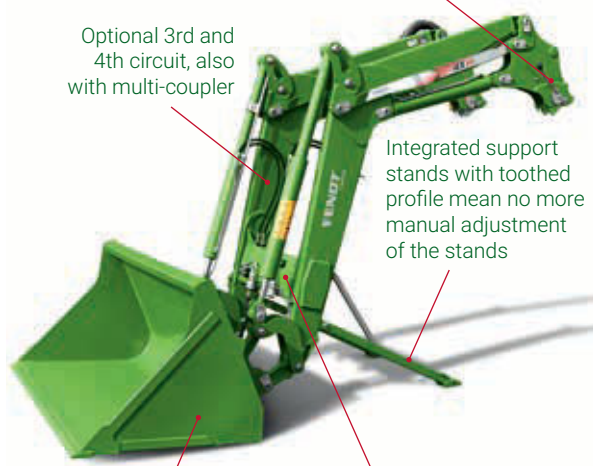

Broad line of Fendt attachments, optimally adapted to the Fendt Cargo

Cross tube protects and houses the valve assembly and damping containers



Storage location: the fully integrated ball holder on the inner mudguard.



Full wheel protection with extra-wide mudguard at the rear and side—keeps out the dirt



Prevents misuse and damage to attached implements: secure the lower link with the shut-off valve.



True ground clearance of up to 19.7 inches—no low parts such as stops or cables

It's time for a warranty that lets you handle fuel and labor,

while we handle everything else.



Nearly 400 years ago, the Fendt family not only built a reputation for fabricating precision clocks, they solidified that reputation by personally servicing and maintaining each one. Like our ancestors, we still believe a great warranty isn't a matter of profit, it's one of pride. The Fendt Gold Star maintenance, service, and warranty program is the best in the business, with a commitment to uptime all the time. It's also a warranty designed to maintain exceptional resale value.

The warranty

Three years or 3,000 hours, including all scheduled routine maintenance and all other repairs, as required.

The parts

Fendt dealers use only genuine AGCO® parts, so your Fendt is always 100% Fendt.

The service

Fendt dealers and their certified technicians use only the highest-caliber diagnostic tools.

The loaner

If your tractor can't be repaired in 48 working hours, we'll provide you with a loaner tractor. We stand by this promise for three years or 3,000 hours.



Gold Star+ (Optional)

For longer working periods, you can extend the standard Gold Star offering with Gold Star+. All the same benefits but for as long as five years or 5,000 hours.



Equipment Packages

Standard and optional equipment

Standard: ■

Optional: □

	Power	Profi	Profi+
Engine			
Preheater unit (engine, transmission oil)	□	□	□
Transmission			
Shuttle function, stop-and-go function	■	■	■
Reverse Alarm	□	□	□
Guidance system			
Guidance system basic package			■
Standard Trimble / NovAtel			□
RTK Trimble / NovAtel			□
TI Auto			
Contour Assistant			□
Agronomy			
Agronomy basic package			■
Telemetry			
Telemetry basic package		□	□
Machine control			
Machine control basic package		□	■
Section Control			□
Variable Rate Control			□
Vario operation			
Multi-function joystick with cruise control, engine speed memory, automatic modes, controls for hydraulics	■	■	■
3L joystick		□	□
Individual Operation Manager – flexible key assignment	■	■	■
Digital Dashboard	■	■	■
12" terminal with touchscreen and key control		■	■
Second 12" terminal in roof		□	□
Fendt Active steering			■
Cab			
Active charcoal filter	□	□	□
Mechanical cab suspension	□	■	■
Pneumatic cab suspension		□	□
Super comfort seat 3-point belt	□	□	□
Comfort seat, air sprung	■	■	■
Super Comfort Seat, air sprung	□	□	□

	Power	Profi	Profi+
Air-conditioning	■	■	■
Integrated automatic climate control	□	□	□
Split windscreen and door on right	□	□	□
Continuous windscreen	■	■	■
One-piece windscreen and door on right	□	□	□
Rear window wash/wipe	□	□	□
Rear view mirror and wide-angle mirror electrically adjustable, heated		□	□
Auxiliary device holder	□	□	□
Universal mobile phone holder	□	□	□
Universal tablet holder	□	□	□
Radio mounting kit with two stereo speakers	■	■	■
Infotainment package		□	□
Infotainment bundle + 4.1 sound system		□	□
4 camera connections (digital/analogue)		□	□
4 USB ports	□	□	□
Fendt Reaction steering system	■	■	■
Brake level device	□	□	□
Electric battery disconnect switch	□	□	□

	Power	Profi	Profi+
Chassis			
Front axle suspension self-leveling, lockable	■	■	■
Steering brake	■	■	■
Automatic trailer steering axle lock		□	□
Compressed air system 2-circuit system	□	□	□

	Power	Profi	Profi+
4WD / differential locks			
Rear / front differential with 100% disc locking and steering angle sensors	■	■	■

	Power	Profi	Profi+
Power lift			
Sa front power lift, with external control (separate valve)	□	□	□
Comfort front power lift da, with position control, external controls	□	□	□
Comfort front power lift da, with position control and relief control, external controls	□	□	□
Electrohydraulic power lift sa (EHR), with external controls	■	■	■
Externally controlled rear power lift	■	■	■

	Power	Profi	Profi+
PTO			
Rear PTO 540/540E/1000 rpm	■	■	■
External controls for rear PTO	■	■	■
PTO comfort control, electrohydr. preselection	■	■	■

	Power	Profi	Profi+
Hydraulics			
EHS valve actuation crossgate lever, multi-function joystick	■	■	■
EHS valve actuation linear module*	□	■	■
External control for hydraulic control unit at rear	□	□	□
Load sensing system with axial piston pump (110 l/min)	■	■	■
1st and 2nd EHS valve at rear	■	■	■
3rd EHS valve at rear	□	□	□
4th EHS valve at rear or 3rd EHS valve at rear and 1st EHS valve in front	□	□	□
Unpressurised rear return flow	■	■	■
Rear DCUP couplings (connect under pressure)	□	□	□

	Power	Profi	Profi+
Front loader			
Front loader Cargo 4X/75	□	□	□
Front loader Cargo 4X/75 Compact	□	□	□
Front loader Cargo 4X/75 Profi**		□	□

Fendt 300 Vario Series Specifications

		311 Vario	312 Vario	313 Vario	314 Vario
Engine					
Rated hp	kW/hp	60/81	68/91	74/99	85/114
Rated power ECE R 120	kW/hp	74/100	83/113	90/123	97/132
Rated power with DP ECE R 120 (approval rating)	kW/hp				104/142
Maximum power ECE R 120	kW/hp	83/113	90/123	98/133	104/142
Maximum power with DP ECE R 120	kW/hp				112/152
No. of cylinders	number	4	4	4	4
Cylinder bore/stroke	mm	108 / 120	108 / 120	108 / 120	108 / 120
Cubic capacity	cm³	4400	4400	4400	4400
Rated speed	rpm	2100	2100	2100	2100
Max. torque at 1500 rpm	Nm	497	536	571	608
Max. torque with DP at 1500 rpm	Nm				650
Torque rise	%	48.3	41.5	38.9	37.2
Fuel level	gallons	55.5	55.5	55.5	55.5
DEF tank	gallons	6.0	6.0	6.0	6.0

		311 Vario	312 Vario	313 Vario	314 Vario
Transmission and PTO					
Speed range forward	km/h / mph		0.02–40 / 65 ft./hr.–25		
Speed range reverse	km/h / mph		0.02–25 / 65 ft./h–15 mph		
Rear PTO			540/ 540E/ 1000		
Rear PTO option (including ground speed PTO)			540/1000/4,2		

		311 Vario	312 Vario	313 Vario	314 Vario
Power lift and hydraulics					
Variable flow pump	l/min / GPM	110/29	110/29	110/29	110/29
Working pressure / control pressure	PSI	2,900	2,900	2,900	2,900
Max. valves (front/centre/rear)	number	0/0/4	0/0/4	0/0/4	0/0/4
Max. valves available as an option (front/centre/rear)	number	1/0/3	1/0/3	1/0/3	1/0/3
Max. available hydraulic oil volume	litres	43	43	43	43
Max. lift capacity of rear power lift	daN	5960	5960	5960	5960
Max. lift capacity of front power lift	daN	3130	3130	3130	3130

		311 Vario	312 Vario	313 Vario	314 Vario
Dimensions					
Front track width (standard tires)	mm	1685	1685	1820	1820
Rear track width (standard tires)	mm	1660	1660	1800	1800
Overall width with standard tires	mm	2220	2220	2320	2320
Overall length	mm	4336	4336	4336	4336

		311 Vario	312 Vario	313 Vario	314 Vario
Weights					
Overall cab height with standard tires without Fendt Guide	mm	2820	2820	2860	2860
Overall cab height with standard tires with Fendt Guide	mm	2870	2870	2910	2910
Max. ground clearance	mm	510	510	510	510
Wheelbase	mm	2420	2420	2420	2420
Unladen weight (base tractor with cab - full tanks, without driver)	kg/lbs.	4,850/10,692	4,850/10,692	5,010/11,045	5,010/11,045
Max. permissible overall weight	kg/lbs.	8,500/18,739	8,500/18,739	8,500/18,739	8,500/18,739
Max. trailer hitch load	kg/lbs.	2,000/4,409	2,000/4,409	2,000/4,409	2,000/4,409



FENDT

fendt.com | Fendt is a worldwide brand of AGCO.



FENDT 300 VARIO SERIES

 **AGCO** | **AGCO ANSWERS**
Your Agriculture Company | (877) 525-4384 AGCOanswers@AGCOcorp.com

AGCO may at any time, and from time to time, for technical or other necessary reasons, modify any of the data, specifications or warranty of the products described herein. Some equipment shown may be optional. Attention: Photographs in this publication may show protective shields and guards open or removed for the purposes of illustration. Be certain all shields and guards are in place during operation.

© 2021 AGCO Corporation. Fendt is a worldwide brand of AGCO Corporation. AGCO®, Fendt®, Fendt Connect™ and VisioPlus™ are trademarks of AGCO. All rights reserved. FT21B007AG